

INTEGRATED DIRECTIONAL UNIT

SNEHIL SURESH WAKCHAURE

SRINIDHI SREEPAD

PRATHEEK RAJAT

AJITH ERABELLY

ABSTRACT

The 'Integrated Directional Unit' is an ECE511 Fall 2011 Class project wherein we as graduate students wished to learn more about microprocessors and their practical implementation. We would like to thank Dr. Kaps to have introduced hardware projects this semester. We started with zero experience on microprocessors and had a good learning experience to successfully implement our project on the MSP430.

The motivation for this project comes from the offshore upstream Oil & gas industry. The Measurement While Drilling tools implement this technology and the 'Integrated directional unit' is at the heart of these highly precise measurement and data acquisition systems used on Oil rigs to support Oil exploration. The systems used on field are highly precise and high temperature resistant although we only wish to study the microprocessor, the sensors, and communication protocols through this class project.

Our goal for this project was to learn, and although all members in the team were very new to hardware projects using a microprocessor, we chose this project which involved sensors such as accelerometer giving PWM outputs which needs Timer operation knowledge, a magnetometer which needs I2C protocol implementation, a Piezo sensor which needs port interrupt programming, a UART unit and LCD unit requiring port & PC communication alongwith Realterm port listener software.

Although it has been a challenging task, we had a great learning experience which every member of our team values a lot. The project also gave an opportunity to work as a team towards a common goal and solve problems as a team along with project planning aspects. We value these learnings a lot over our successful implementation of the proposed tasks. We feel content that each one of us was so dedicated towards this common goal which lead to successful implementation of this project. We were able to implement all the modules successfully and are confident about complete system integration given we change the microprocessor chip to MSP430F2272 which has 2 timers and USCI unit instead of MSP430G2231 which we are using currently. But for now, we demonstrate the system using the MSP430G2231.

CONTENTS

Sr. no	Title	Pg. no
1	ABSTRACT	2
2	CONTENTS	3
3	MOTIVATION	4
4	THE SYSTEM	5
5	SYSTEM COMPONENTES & INTERFACING	5
6	ACCELEROMETER +UART	5
7	MAGNETOMETER	7
8	PIEZO SENSOR	8
9	LCD	8
10	RESULTS & CONCLUSIONS	9
11	APPENDIX: List of Project Members and their tasks:	10
12	APPENDIX: COMPLETE PARTS LIST	10
13	APPENDIX: SCHEMATIC	11

MOTIVATION



The motivation for this project comes from the offshore upstream Oil & gas industry. The Measurement While Drilling tools implement this technology and the 'Integrated directional unit' is at the heart of these highly precise measurement and data acquisition systems used on Oil rigs to support Oil exploration. The systems used on field are highly accurate & temperature resistant although we only wish to study the microprocessor, the sensors, and communication protocols through this class project.

MWD stands for Measurement While Drilling in the oil industry. It is a system developed to perform drilling related measurements downhole and transmit information to the surface while drilling a well. MWD tools are conveyed downhole as part of bottom hole assembly (BHA). The tools are either contained inside a drill collar (sonde type) or are built into the collars themselves. The Integrated Directional Unit (IDU) is a part of the MWD system and provides directional information to the surface and exploit highly sensitive accelerometers and magnetometers for the same to give the directional information in the form of inclination angle and azimuth angle. Our main motivation has been to learn through this class project.

THE SYSTEM

The following is the block diagram for the proposed system:

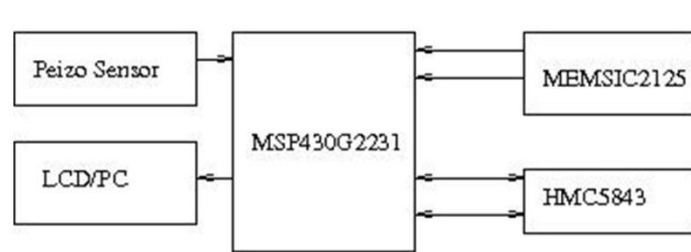

BASIC BLOCK DIAGRAM

The above block diagram demonstrates the proposed system. The MEMSIC 2125 accelerometer measures static acceleration on two axes and sends the readings to MSP430G2231. The HMC 5843 magnetometer measures the Earth's magnetic field on 3 axes and communicates with MSP430 G2231 using the I2C protocol. The Piezo sensor uses one of the ports to send vibration detection signal. The UART unit sends the sensor readings to the PC while the LCD is used to display them.

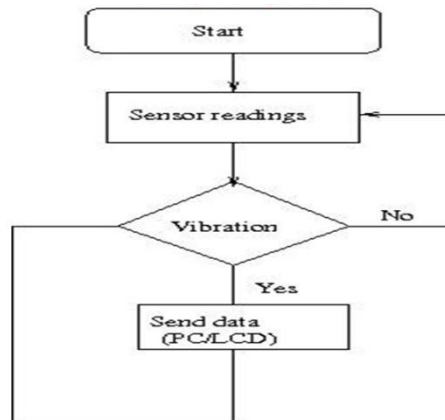

SYSTEM COMPONENTS & INTERFACING

MEMSIC2125 Accelerometer:

The Memsic 2125 is a low cost, dual-axis thermal accelerometer capable of measuring tilt, acceleration, rotation, and vibration with a range of ± 3 g. There are 2 methods of interfacing the MEMSIC2125 with the MSP430G2231, namely using timer capture and using port interrupt. The hardware and software interface for both of these is mentioned below.

Features (MEMSIC2125 DUAL AXIS ACCELEROMETER):

- Measures ± 3 g on each axis
- Simple pulse output of g-force for each axis

- 100 Hz PWM output signal with duty cycle proportional to acceleration
- Low current at 3.3 or 5 V operation: less than 4 mA at 5 VDC

MEMSIC2125 Hardware Interface (Using Timer)

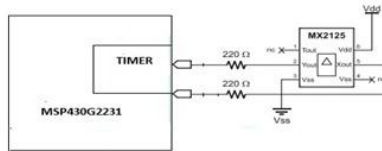

MEMSIC2125 Hardware Interface: (Using Port1 Interrupts)

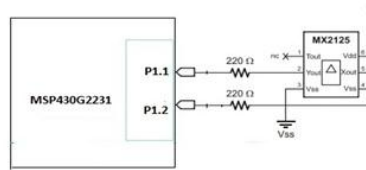

Software Interface (Pseudocode)

Software Interface (Using Port Interrupts)	Software Interface (Timers)
Configure 2 port pins to get PWM input from the Accelerometer Detect rising edge using port interrupt Within the Timer ISR: Check if rising edge Capture Start time from TAR Switch to falling edge capture settings If falling edge, then Capture Stop time from TAR Switch to rising edge Reset TAR Progress: Rising edge and falling edges detected	MEMSIC2125 Software Interface: (Using Timer) Configure the Timer to operate to capture rising edge, SMCLK, CCIE=1 Within the Timer ISR: Check if Rising edge Capture Start time Switch to falling edge capture settings If falling edge, then Capture Stop time Switch to rising edge Progress: Rising edge and falling edges detected, start and stop times captured, ISR coded Waveforms tested on CRO, Values checked on IAR Testbench software

UART:

WE changes the demo temperature program from TI website to extract eh code for UART and use it to send single and multiple bytes to the PC.

MAGNETOMETER

The HMC5843 is a surface mount multi-chip module designed for low field magnetic sensing with a digital interface for applications such as low cost compassing and magnetometer. The HMC5843 includes the state of the art 1043 series magneto-resistive sensors plus Honeywell developed ASIC containing amplification, strap drivers, offset cancellation, 12-bit ADC and an I2C serial bus interface. The HMC5843 is in a 4.0 by 4.0 by 1.3mm surface mount leadless chip carrier (LCC). Applications for the HMC5843 include Consumer Electronics, Auto Navigation Systems, Personal Navigation Devices, and Magnetometers.

Features of HMC5843:

- Low Voltage Operations (2.5 to 3.3V)
- Low Cost
- I2C Digital Interface
- Used as Slave
- Supports 100kHz to 400kHz data speed
- Gives X, Y, Z values



We use the I2C communication protocol to communicate with the MSP430 and the Magnetometer HMC5843. Here the MSP430 acts as the master receiver and the HMC5843 acts as the slave transmitter. The detailed I2C software protocol is given below

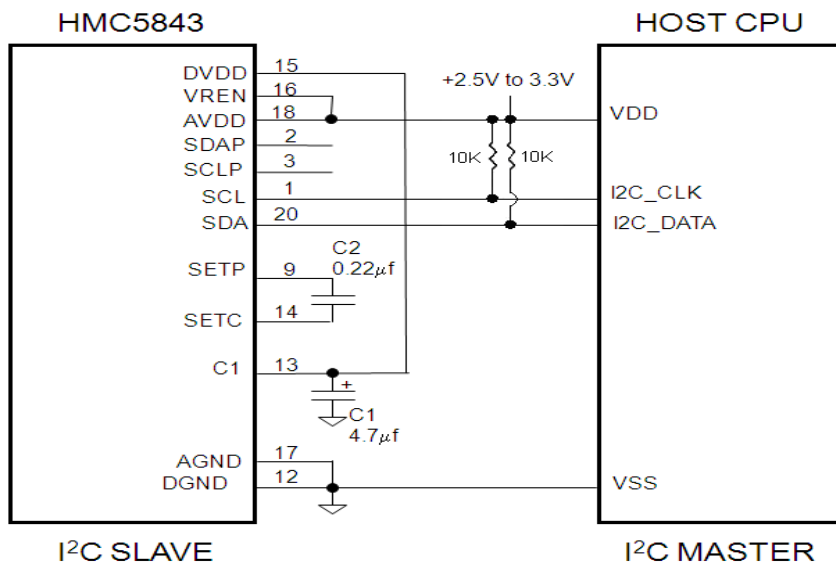

The I2C Software Protocol: The first thing that will happen is that the master will send out a start sequence. This will alert all the slave devices on the bus that a transaction is starting and they should listen in case it is for them. Next the master will send out the device address. The slave that matches this address will continue with the transaction, any others will ignore the rest of this transaction and wait for the next. Having addressed the slave device the master must now send out the internal location or register number inside the slave that it

wishes to write to or read from. This number is obviously dependent on what the slave actually is and how many internal registers it has. Some very simple devices do not have any, but most do, including all of our modules. Having sent the I2C address and the internal register address the master can now send the data byte (or bytes, it doesn't have to be just one). The master can continue to send data bytes to the slave and these will normally be placed in the following registers because the slave will automatically increment the internal register address after each byte. When the master has finished writing all data to the slave, it sends a stop sequence which completes the transaction.

To read to a slave device:

- Send the Start Sequence
- Send the Slave write address 0x3C
- Send the mode register address 0x02
- Send mode register configuration 0x00
- Send Slave read address 0x3D
- Send the address of the register to be read 0x03
- Read Data from the slave
- Stop sequence

The values are saved in the USISRL register. These values are used to compute the angles of the magnetometer with respect to the true north.

The maximum value of Hx and Hy depend on the strength of the earth's field at that point.

Direction (y>0) = $90 - [\text{arcTAN}(x/y)] * 180/\pi$

Direction (y<0) = $270 - [\text{arcTAN}(x/y)] * 180/\pi$

Direction (y=0, x<0) = 180.0

Direction (y=0, x>0) = 0.0

To determine true north heading, add or subtract the appropriate declination angle.

LCD INTERFACE

Hard-Ware Interface:

- We have used LCDADM1602k.
- Hardware interface is similar to the Schematic diagram as show in the figure appendix.
- Generally, Lcd is interfaced to MSP430 through the port-number 1.0 to 1.7 and it makes use of 6 ports of msp430.
- As we are using port 1.0 and 1.1 for the accelerometer and 1.6 and port 1.7 for magnetometer as fixed, we have interfaced the lcd using the ports 2.0, 2.1 and 2.5.

Software interface:

- IT doesn't use any kind of timers, that's why we have shifted from urlt to LCD display.
- With the help of lcd code attached with the document , we have calculated the end value like TILT from the TON

RESULTS & CONCLUSIONS

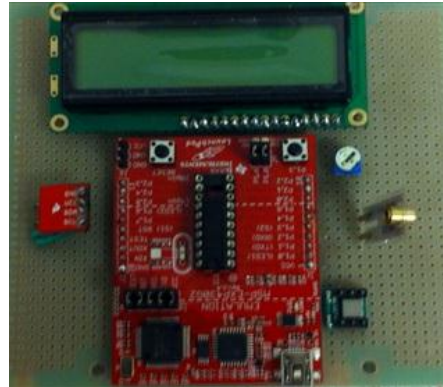

All of the system components are working as expected. We are able to interface them successfully with MSP430G2231 as per the interfaces mentioned in this report. The accelerometer, UART, magnetometer, LCD, Piezo sensor codes are attached. We are very confident about doing the integration too, but we realized later during project development phase that a proper choice of MSP430, namely MSP430F2272 due to its 2 timers (convenient for system integration as UART and accelerometer uses timers and for I2C communication due to USCI feature). Apart from complete system integration, the system works as expected.

The **MEMSIC2125 accelerometer** hardware and software interface with MSP430 and integration with the PC using UART is successfully integrate

MAGNETOMETER: We used the I2C communication to interface the magnetometer and MSP430. The MSP430G2231 supports only the Universal Serial Interface (USI). So we had limited registers to communicate with the magnetometer. It was a challenge for us to read the values from the magnetometer. The MSP430 had to read the x, y and z values from the magnetometer.

We successfully interfaced the two components. But we had problems in reading the data from the magnetometer. But we overcame this problem by introducing the delays between each read signal. So we got the values from the magnetometer, from which we had to compute the magnetic field angles.

PIEZO VIBRATION SENSOR: Working of sensor is successfully implemented and thus we could sense the incoming vibrations. Communicating with the MSP430G2231 is done using port interrupts and connections to the MSP430G2231 is done using wires.

APPENDIX:

List of Project Members and their tasks:

- a) SNEHIL SURESH WAKCHAURE: Accelerometer MEMSIC 5125, Software communication-UART and Integration.
- b) SRINIDHI SREEPAD: Worked on Magnetometer HMC 5843.
- c) PRATHEEK RAJATH : Worked on Piezo Vibration Sensor and I2C in Magnetometer.
- d) AJITH ERABELY: Worked on LCD Display, Calculations for Accelerometer & Magnetometer

Complete Parts List:

Sr No	COMPONENTS	MODEL No	ACQUIRED	COST
1	Accelerometer	MEMSIC 2125	OCT 3rd	\$34
2	Magnetometer	HDMC 5823	Reordered	\$29
3	Piezo Vibration Sensor	MEAS	OCT 20th	\$3
4	LCD	ADM1602K	NOV 28th	\$12
5	Accelerometer	ADXL345	NOV 1st	\$14

SCHEMATIC:

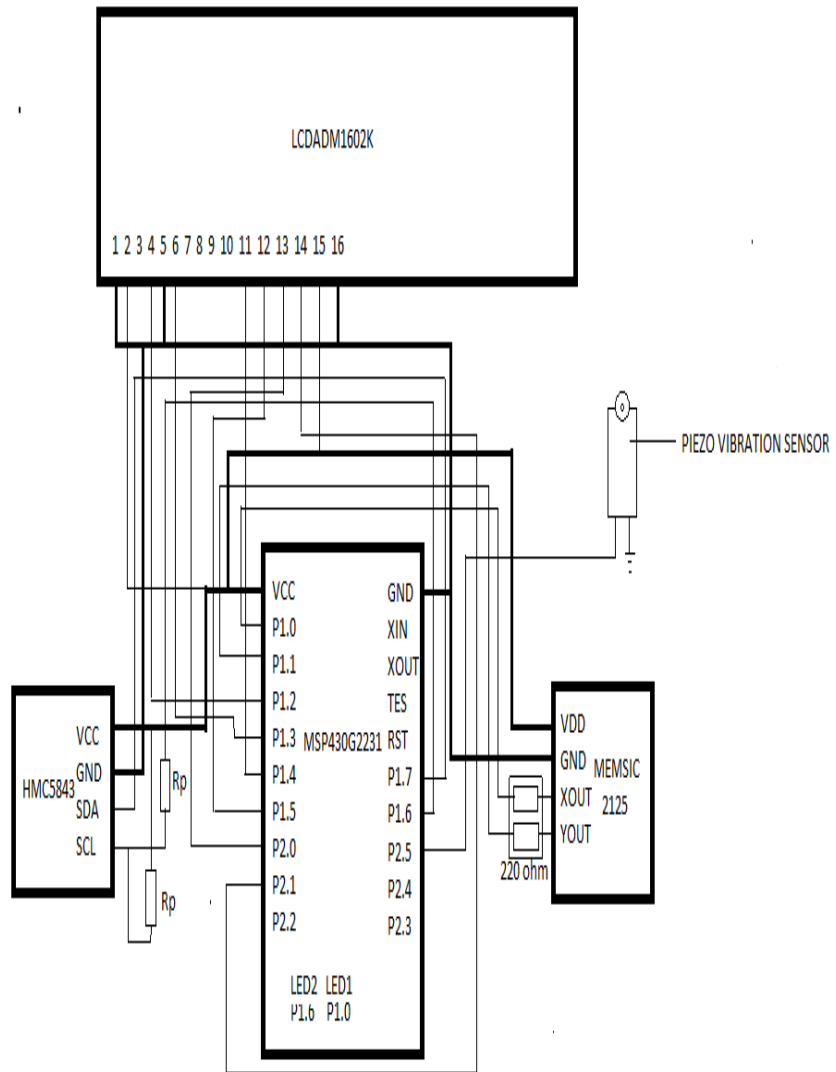

PROJECT PLANNING:

We have met all the project deadlines as promised during class presentations.