

TONGUE DRIVE SYSTEM

Dhanavanthri, Swathi
Gollapudi, Parimala
Nagamalla, Vamshi Krishna
Routhu, Anshul



Where Innovation Is Tradition

OVERVIEW

- Tongue is the least effected part in our body
- It is also the most flexible part in our body
- A tongue driven system is very much useful to patients who are paralyzed or handicapped as they can drive the system(wheel chair) with their tongue without much effort.



BLOCK DIAGRAM

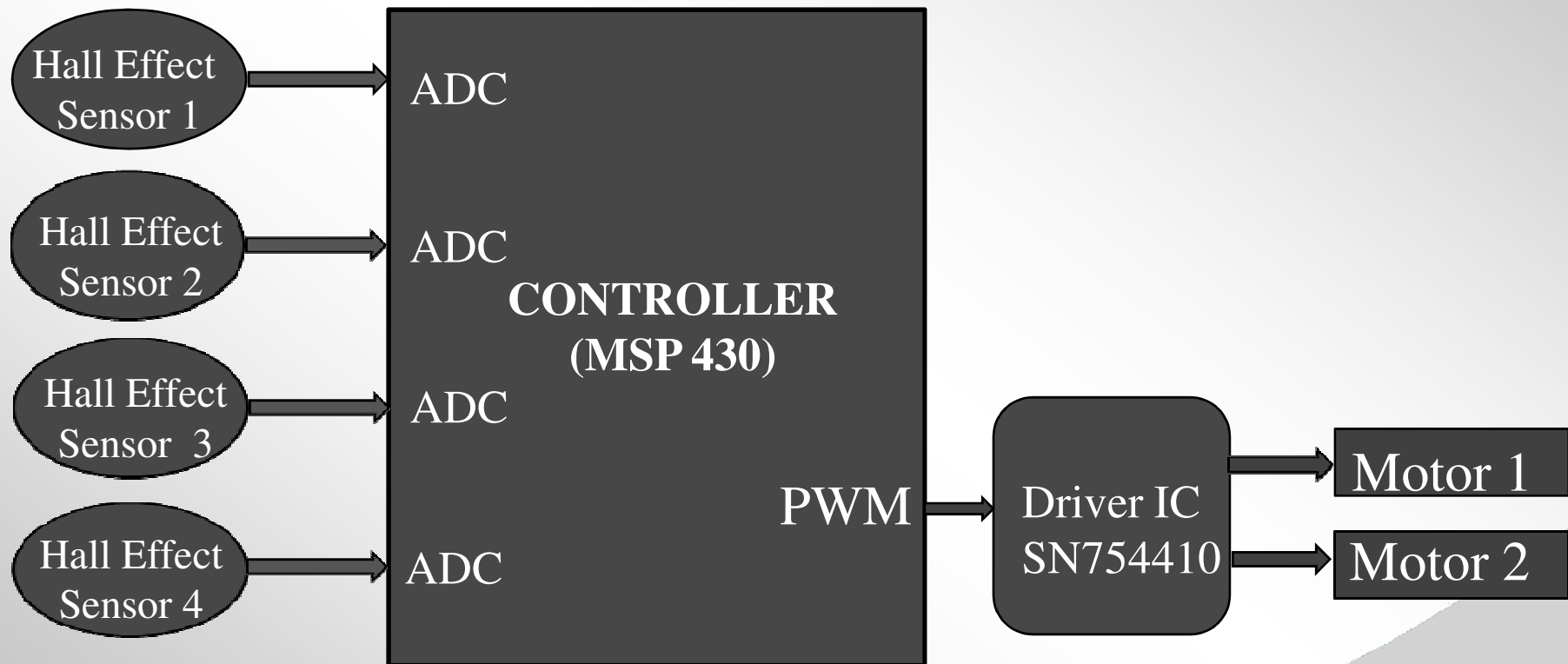

BLOCK DIAGRAM

- The hall effect sensor generates analog signal proportional to magnetic field.
- The ADC converts the analog values into digital
- The controller configures the PWM in accordance to the software(algorithm)
- The PWM controls the speed of the motor
- The H-Bridge driver drives the motor in Both directions.

Hall Effect Sensor:

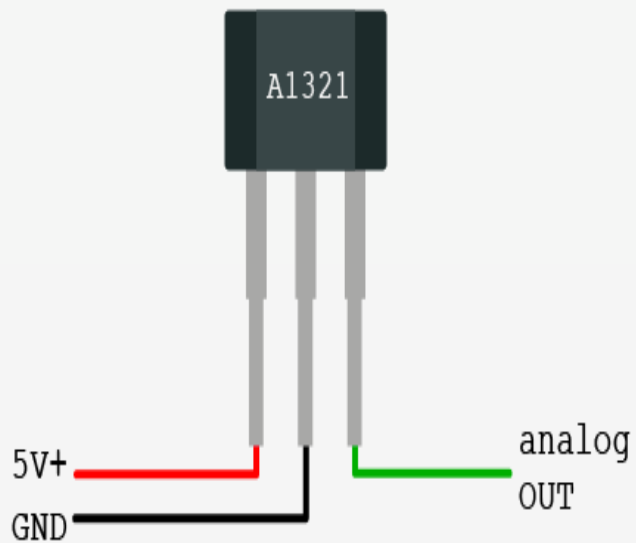

- A1321 Linear Bipolar Hall Effect Sensor
- Hardware interface ADC
- Component Tested

H-Bridge Driver: SN754410

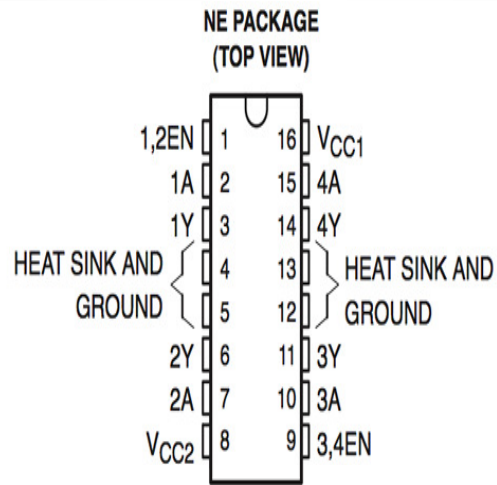

- SN754410 is a bi directional driver and can drive two motors at a time.
- Hardware interface PWM
- Component Tested

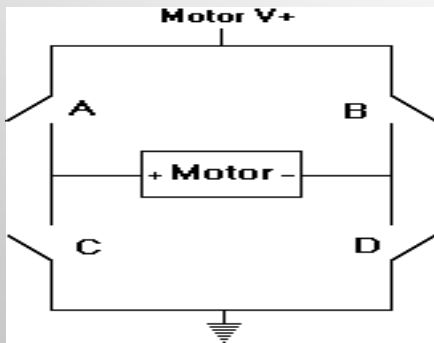

PROGRESS

- Initial research on the project completed.
- The hardware block diagram has been finalized.
- All the required components were bought and tested.
- Initial work on algorithm started

TASKS TO BE COMPLETED BY NEXT MEETING

- All the Hardware interfacing will be completed
- The algorithm will be finalized.
- Algorithm → Software (Hopefully)
- As of now , variable speed with motion in all directions planned
- As a plan B, a simple algorithm will be developed in which there will be only one direction with fixed speed.